



Magnetek's E-Force Solar grid-tied systems are designed for large solar applications such as "big box" retail, office buildings, industrial facilities or ground mount installations. Harvest more green with E-force's Maximum Power Point Tracking (MPPT) algorithm that maximizes energy produced under varying light conditions. The revolutionary switching technology utilized in the E-Force large-scale inverter includes state-of-the art Insulated Gate Bi-polar Transistors (IGBTs) to reduce switching losses.

E-Force has been designed with large de-rating criteria on all critical components, achieving an extremely robust and reliable inverter designed to last for 25 years and to deliver true maximum output power on a continuous basis. With this design concept, E-Force achieves peak efficiencies of over 97.6%. Total current harmonic distortion is typically less than 3% through E-Force's control switching technology.

SMART CONTROLS

E-Force controls are Digital Signal Processor (DSP) based with sophisticated control and self-diagnostic algorithms. An LCD display shows the unit's operating status and a built-in Data Logger records and sends daily performance and operational data.

BENEFITS

- Dual MPPT (450 – 850 VDC)
- NEMA 2/IP11, NEMA 4X (optional) installed in ruggedized, sealed enclosure to withstand harsh environmental conditions
- Compact size and high power density: 1 MW of output power in a box just 100"H x 183"W x 31"D
- Rear air-cooled heatsink keeps the unit cleaner and more efficient over time
- Isolation transformer (optional) is dependent upon utility interconnection
- High overload capability works up to 50° C before derating
- True Sine Wave Output
- Optional FERC 661A for ride-through
- IEEE1547 Certified grid-connected operation according to UL1741
- LCD display on the front to monitor the main parameters
- DC input options include positive grounded, negative grounded, and floating array designs

BLOCK DIAGRAM

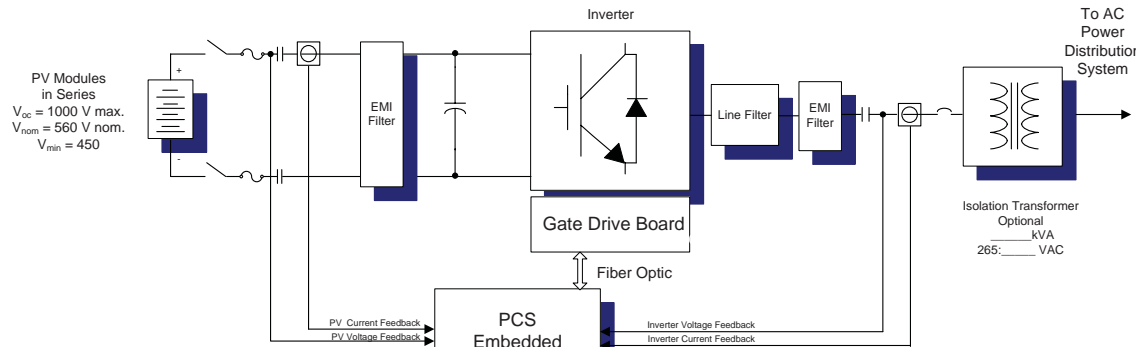

TYPICAL EFFICIENCY [%]

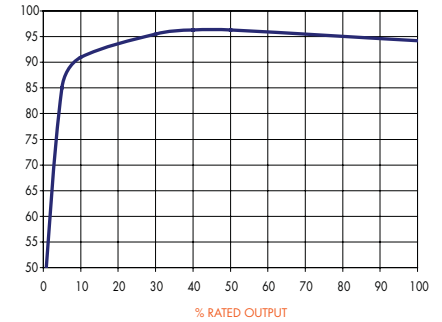

CHARACTERISTICS	PVI-500	PVI-1 MW
Power Rating (kW)	500	1000
DC Power Rating	520	1040
Open Circuit Voltage Range (Vdc)	450-1000 (560 nominal)	450-1000 (560 nominal)
Power Tracking Window Range (Vdc)	450-850 (560 nominal)	450-850 (560 nominal)
Array Configuration	Mono-pole with multiple string fusing options available	Mono-pole with multiple string fusing options available
Nominal AC Voltage Range (Vms)	3-phase 265VAC (isolation transformers can be specified to meet interconnection requirements)	3-phase 265VAC (isolation transformers can be specified to meet interconnection requirements)
Nominal AC Frequency (Hz)	50/60	50/60
Line Power Factor	.95*	.95*
Maximum AC Line Current (Ams)	1240	2480
AC Current Distortion (%)	<3% THD at rated power	<3% THD at rated power
Max Efficiency (%)	>97.6	>97.6
Tare Losses (W)	<375	<375
Operating Ambient Temperature (°C)	-40 to +50	-40 to +50
Enclosure Environmental Rating	NEMA2/IP11	NEMA2/IP11
Relative Humidity	0 — 95% Non-condensing	0 — 95% Non-condensing
Elevation	Derated above 6,600ft (2,000m)	Derated above 6,600ft (2,000m)
Audible Noise (dBA)	<80	<80
Size (Inches)	100"H x 130.9"W x 31"D	100"H x 183"W x 31"D
Weight (Lbs)	4,500	6,500

* Extended range power factor available

MODEL SUMMARY AND ORDERING CODES	
Model Number	Power
PVI-500	500 kW
PVI-1 MW	1 MW
Options Suffix	Description
-T	Transformer
-W	Weather Station



MAGNETEK
RENEWABLE ENERGY

N50 W13605 Overview Drive
Menomonee Falls, WI 53051
p 866.381.2035
f 262.790.4142

Magnetek (UK) Ltd.
20 Drake Mews, Crownhill
Milton Keynes, Buck MK8 0ER UK
p +44(0) 1908 261427
f +44(0) 1908 261674

magnetekrenewableenergy.com

© 2009 Magnetek, Inc.
Pub No. E-FORCE_SOLAR

BEST-IN-CLASS COMMUNICATION CAPABILITIES

E-Force ethernet connection allows several units to work in parallel and records data from each unit and stores the data to be transmitted daily over modem or optional Internet access.

STANDARDS AND CODES

E-Force inverters comply with standards set for grid-tied operation, safety and electromagnetic compatibility: UL1741 (Pending), NEC690, IEEE1547, IEC61683, IEC61727, EN50081, FERC661A.